

LOC	DIST	REVISIONS					
AF	50	P	LTR	DESCRIPTION	DATE	DWN	APVD
		D		REV PER ECR-06-001928	24APR06	HMR	KR

1 CONTINUOUS STRIP ON REELS.
 2 TIN PLATE 0.00381 [.000150] MIN OVER 0.00254 [.000100] MIN THK COPPER OR TIN PLATE 0.00381 [.000150] MIN OVER 0.00127 [.000050] MIN THK NICKEL.

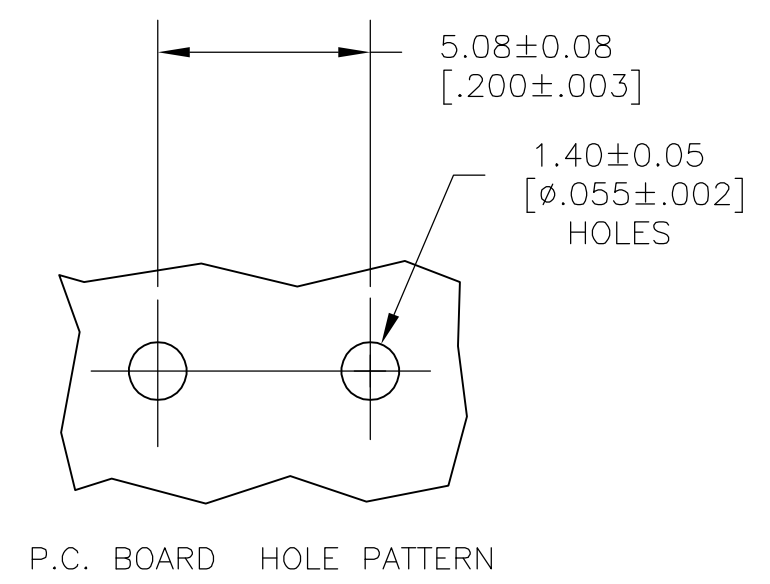
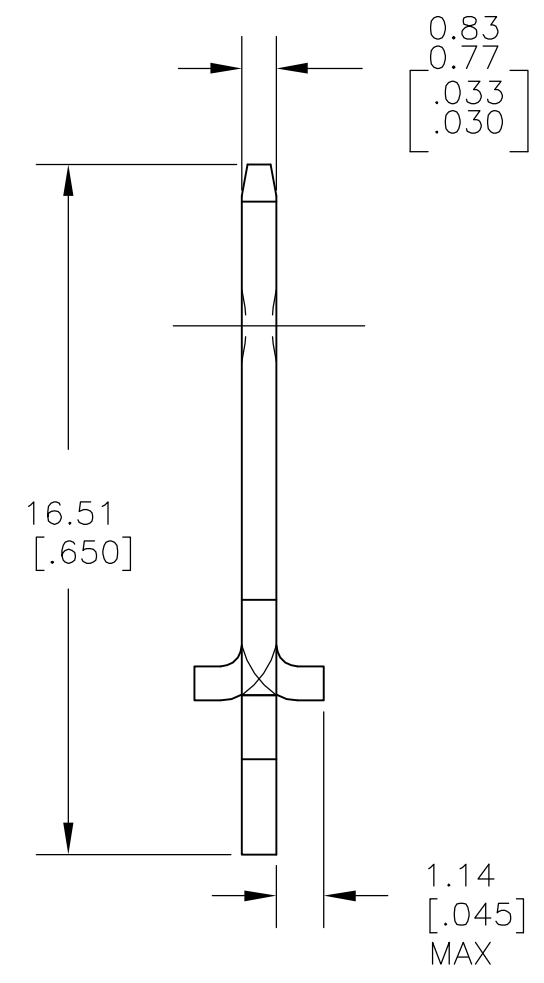
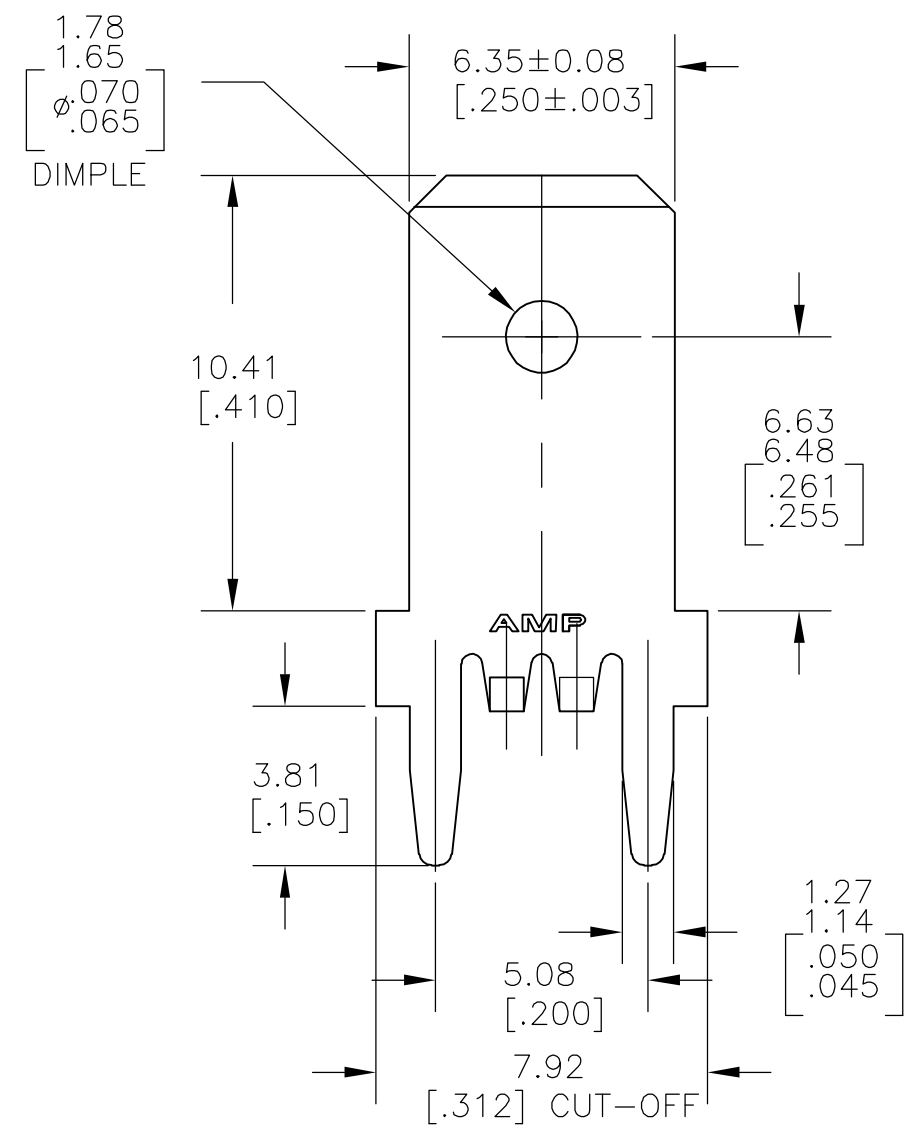

1217126-1
 PART NO.

THIS DRAWING IS A CONTROLLED DOCUMENT.		DWN	JR RUTH	28MAR01	 Tyco Electronics Corporation Harrisburg, PA 17105-3608	
DIMENSIONS: mm [INCHES]		CHK	MS FEHER	28MAR01		
TOLERANCES UNLESS OTHERWISE SPECIFIED:		APVD	N DEIBERT	28MAR01		
0 PLC ± - 1 PLC ± - 2 PLC ± 0.25 [.010] 3 PLC ± - 4 PLC ± - ANGLES ± -		PRODUCT SPEC	NAME			
MATERIAL	082 BRASS	FINISH			TAB, FASTON, P.C.BOARD 6.35 [.250]	
WEIGHT		-		SIZE	A3	
CUSTOMER DRAWING		CAGE CODE	00779		DRAWING NO	C-1217126
SCALE		6:1		SHEET	1 of 1	
RESTRICTED TO		-		REV	D	